

VingCard Energy Control Units: The intelligent choice to save money

VingCard offers a complete range of in-room Energy Control Units, the perfect combination to provide in-room comfort to your guests and saving energy and money when the guests are not in their room.

Compatible with the same VingCard room keycard, and intelligent to differentiate guest keycards and staff keycards. Thus, limiting the use of air conditioning and other electrical equipment in the room only to your guests and not to your hotel staff.



The ECU only operates with hotel specific keycards (this feature is not available for the Standard model).



BENEFITS:

- Disconnects electrical equipment and air conditioning when guests are outside the room, thus saving money.
- Courtesy timer for guests when removing the keycard from the Energy Control Unit.
- Simple installation
- LEDs for easy location when entering the room
- Own power supply with minimum consumption (10m/Amp in stand-by and 20m/Amp when on).
- It only works with hotel specific keycards (*).
- Can prevent hotel staff from using certain electrical equipment in the room (Air Conditioning, TV, phone, etc...) while cleaning up the rooms (*).

(*) only for Intelligent Magnetic Stripe and Intelligent RFID.

TECHNICAL FEATURES

| | STANDARD | INTELLIGENT MAGNETIC STRIPE | INTELLIGENT RFID |
|------------------------|--|--|--|
| Descriptions: | Mechanical temporized energy saver. | Only operates with hotel specific magnetic striped keycards. | Only operates with hotel specific RFID keycards. |
| Guest/Staff keycard | | It prevents hotel staff from using certain electrical equipment in the room (air conditioning, TV, phone etc.) while cleaning the rooms. | It prevents hotel staff from using certain electrical equipment in the room (air conditioning, TV, phone etc.) while cleaning the rooms. |
| Voltage: | 110/220 Vac. Tolerance 10 %. | 110/220 Vac. Tolerance 10 %. | 110/220 Vac. Tolerance 10 %. |
| Consumption: | | Nominal of 10 m/Amp. Max. of 20 m/Amp. | Nominal of 10 m/Amp. Max. of 20 m/Amp. |
| Frequency: | 50-60 Hz. | 50-60 Hz | 50 - 60 Hz. |
| Output relay: | 1 relay. Power of cutting: 10 A, 250 V-, cos = 1 6 A, 250 V-, cos = 0,6 Incandescent max. load 8 A - Halogen max. load 8 A | 2 relays. One according to the power supply and other potential free. Power of cutting: 10 A, 250 V-, cos = 1 6 A, 250 V-, cos = 0,6 Incandescent max. load 8 A - Halogen max. load 8 A | 2 relays. One according to the power supply and other potential free. Power of cutting: 10 A, 250 V-, cos = 1 6 A, 250 V-, cos = 0,6 Incandescent max. load 8 A - Halogen max. load 8 A |
| Size mm: inch: | Height 132 • Width 97 • Depth 35 Height 5,20 • Width 3,82 • Depth 1,38 | Height 132 • Width 97 • Depth 35 Height 5,20 • Width 3,82 • Depth 1,38 | Height 132 • Width 97 • Depth 35 Height 5,20 • Width 3,82 • Depth 1,38 |
| Weight grams pounds | 186 grams 0,41 | 210 grams 0,46 | 210 grams 0,46 |
| Box: | FIREPROOF material (BG3(H)) according to norm UL 94 V-0. | FIREPROOF material (BG3(H)) according to norm UL 94 V-0. | FIREPROOF material (BG3(H)) according to norm UL 94 V-0. |

Standard Connecting Diagram:

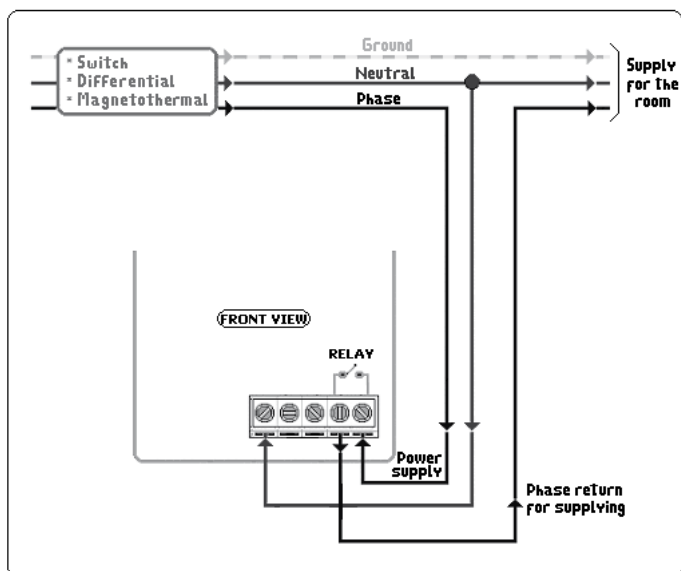

Intelligent Magnetic Stripe and RFID Connecting Diagram:

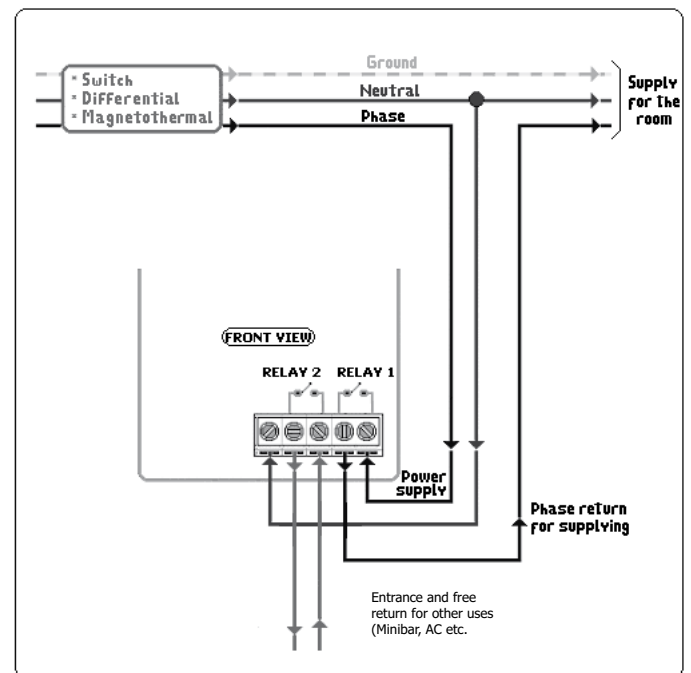

Unlimited possibilities •
customized solutions

Accessories
by VingCard®

Contact us:



ASSA ABLOY

VingCard Elsafe AS

P.O. Box 511 • 1522 Moss • Norway

Tel: +47 69 24 50 00 • Fax: +47 69 24 50 50

E-mail: info@vcegroup.com • www.vcegroup.com